

REV	DESCRIPTION	DATE	DRAWN	APPROVED
C	ECO-0002313	2011/12/21	MAY	ERIC
D	ECO-0002496	2012/01/31	HARRY	FRED
E	ECO-0005132	2017/12/02	LRC	FRED

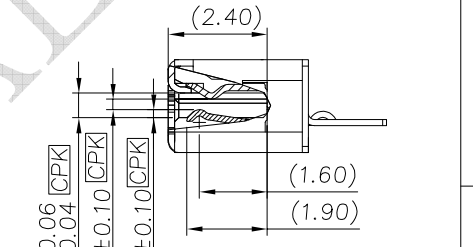

SCALE 2:1

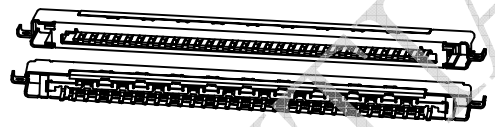
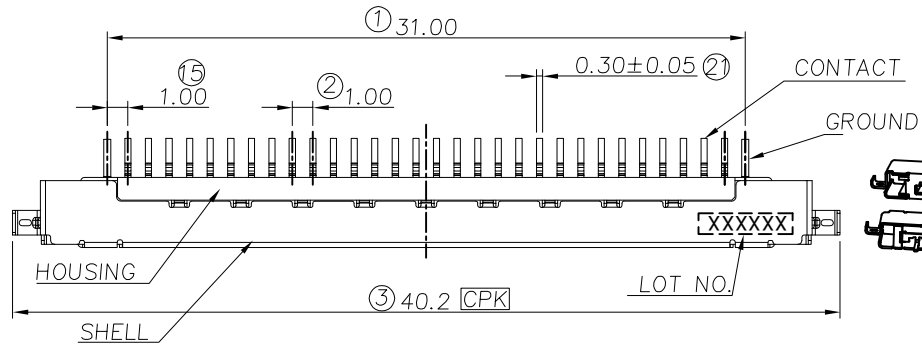
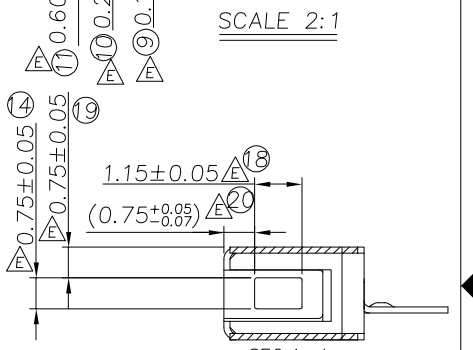
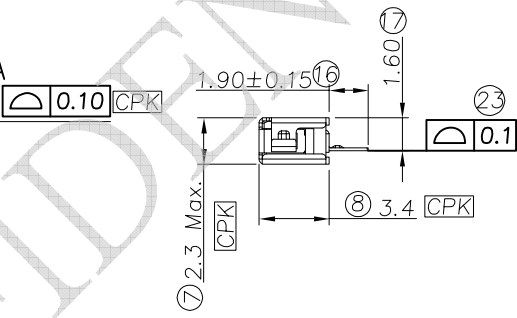
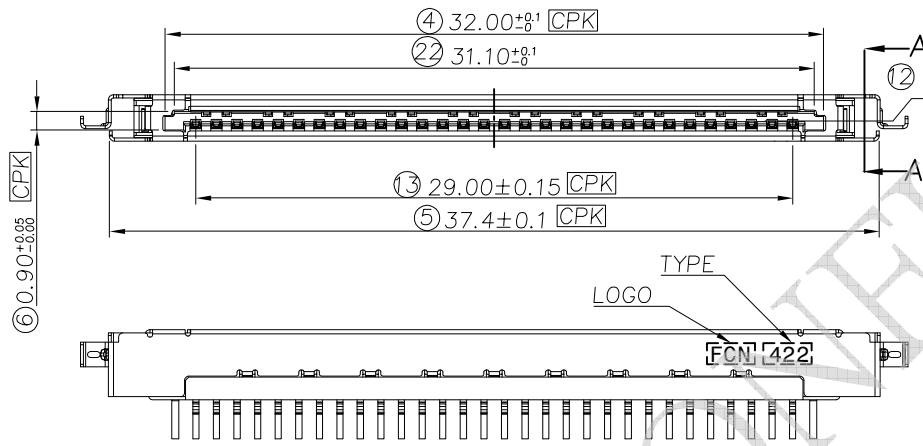

SEC.A-A
SCALE 2:1

NOTES:

- MATERIAL:
 - HOUSING: TERMOPLASTIC UL94V-0, BEIGE
 - CONTACT: COPPER ALLOY, T=0.15mm
PLATING: CONTACT AREA 5u" GOLD
SOLDER AREA 80u"~120u" TIN(LEAD FREE)
OVERALL WITH 50u" NICKEL UNDER PLATED.
 - SHELL: STAINLESS, t=0.15mm
PLATING: SOLDER AREA PLATED WITH GOLD FLASH
 - GROUND: COPPER ALLOY, t=0.15mm
PLATING: TIN(LEAD FREE)
- SPECIFICATIONS:
 - CURRENT RATING: 1A AC,DC
 - VOLTAGE RATING: 200V AC,DC
 - WITHSTANDING VOLTAGE: 500V AC/MINUTE.
 - INSULATION RESISTANCE: 100MΩ MIN.
 - CONTACT RESISTANCE: 40mΩ MAX.
 - OPERATING TEMPERATURE: -40°C~+80°C
- P/N: WF13-422-3033

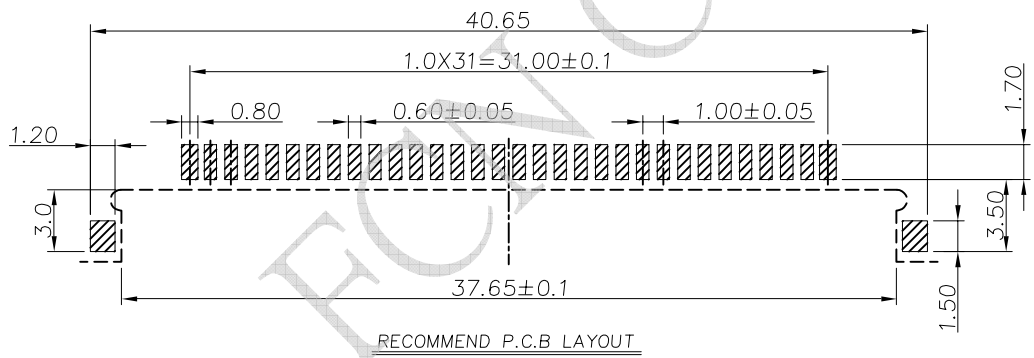

		TOLERANCES :		UNLESS OTHERWISE SPECIFIED; DIMENSIONS ARE IN MILLIMETER. DO NOT SCALE DRAWING.
		DECIMALS.X	± 0.25	
<small>THESE DRAWINGS AND SPECIFICATIONS ARE THE PROPERTY OF FCN GROUP AND SHALL NOT BE PRODUCED, COPIED OR USED IN ANY MANNER WITHOUT THE PRIOR WRITTEN CONSENT OF FCN GROUP.</small>		NAME		
DRAWN LRC		DATE 2017/12/02		
CHECKED FRED		FILE NO. WF13		
APVD FRED		DWG NO. D08-WF13-003		REV E
		CAD NO. D08-WF13-003_1_E		SHEET 1 OF 2

REV	DESCRIPTION	DATE	DRAWN	APPROVED
A	ECO-0001117	2010/07/07	MAY	ERIC
B	ECO-0001610	2011/03/17	MAY	ERIC

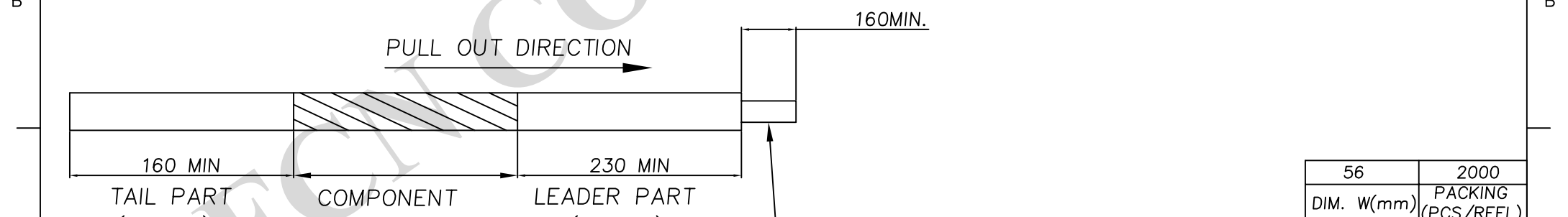
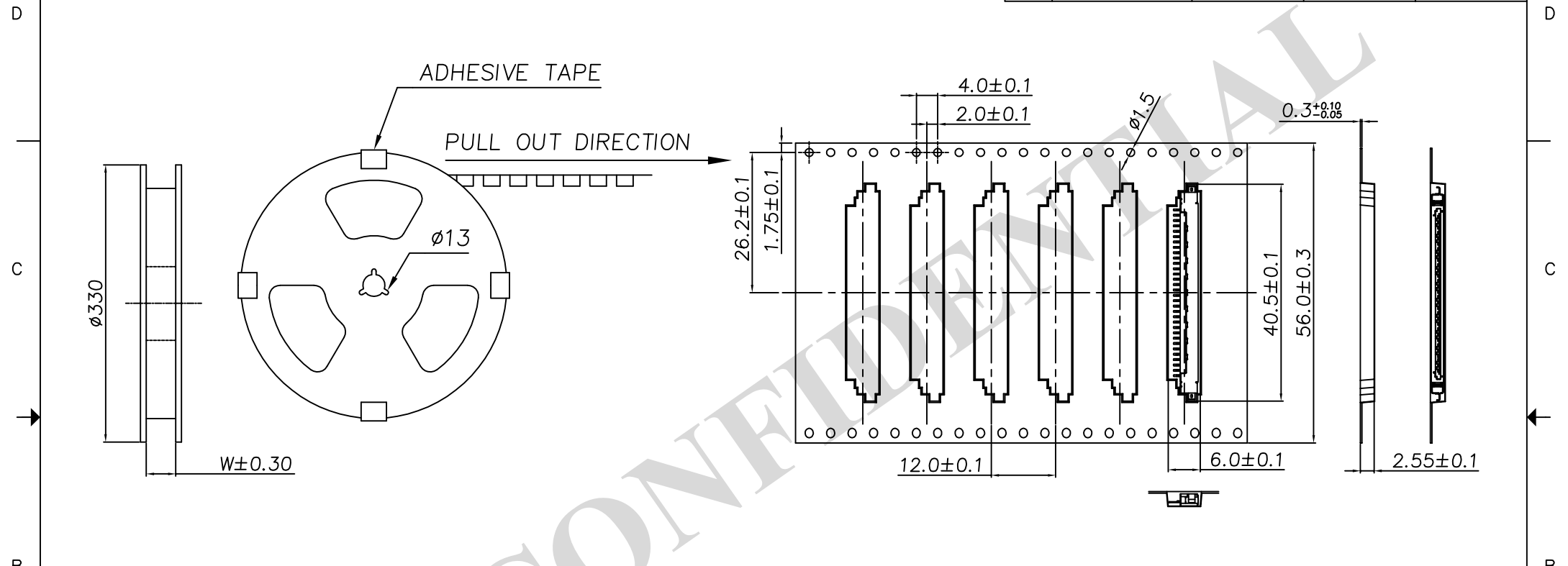

56	2000
DIM. W(mm)	PACKING (PCS/REEL)

FCN

THESE DRAWINGS AND SPECIFICATIONS ARE THE PROPERTY OF FCN GROUP AND SHALL NOT BE PRODUCED, COPIED OR USED IN ANY MANNER WITHOUT THE PRIOR WRITTEN CONSENT OF FCN GROUP.

TOLERANCES :
 DECIMALS: .x ± 0.25 ANGULAR: x ± 5°
 .xx ± 0.20 .X ± 3°
 .xxx ± .XX ±

UNLESS OTHERWISE SPECIFIED; DIMENSIONS ARE IN MILLIMETER. DO NOT SCALE DRAWING.

NAME: LVDS RECP. P=1.0mm H=2.3mm R/A SMT REVERSE/SINK TYPE 30P

DRAWN: MAY	DATE: 2011/03/17	FILE NO.: WF13	DWG NO.: D08-WF13-003	REV: B
CHECKED: EVA	2011/03/17			
APVD: ERIC	2011/03/17	CAD NO.: D08-WF13-003_2_B	SHEET 2 OF 2	